

FXC7 Series DC Contactor Specification

Customer	General Specification
Product Name	DC Contactor
Part Number	FXC7-400T-P FXC7-400TH-P FXC7-400TC-P
Date	2022/04/01
Validity	2 Year
Version	2022V1.0

DC Contactor

Feature

- Safe**: Fully sealed with epoxy resin, contact and coil will not be oxidized, product performance is not affected by external environment, no arc outbursts, can be worked in explosive and harmful environment.
- Reliable**: Adopt DC high voltage non-polarity design, the breaking capacity is higher and more reliable, convenient and reliable installation or wiring.
- Good for environment**: All components meet the latest ROHS environmental requirements.
- Application**: Ordinary, quick charging, auxiliary contactor. Can be used in EV, charging equipment, photovoltaic system, etc.
- Approval**: UL, CE, TUV

Ordering

FXC7-400 T H - P /XXX

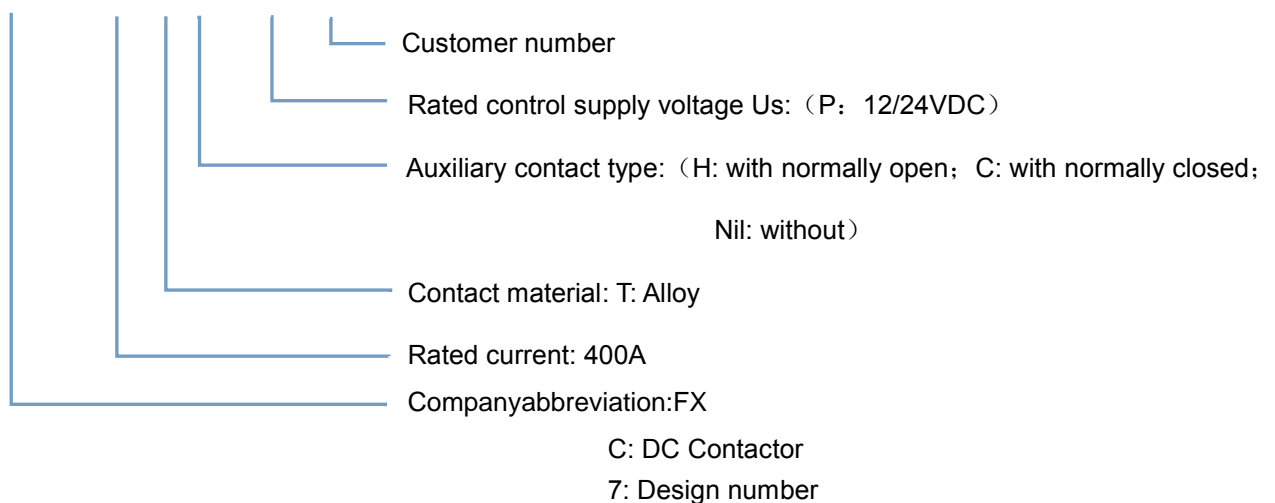

DC Contactor

Basic Parameter

Contact parameter		
Main contact	Rated operational current Ie	400A
	Rated operational voltage Ue	12~1000VDC
	Min. load	1A12VDC
	Main contact type	1SH (SPST NO DM)
	Nominal resistance of main circuit	MAX 30mV (@100A)
	Main contact mounting	M8 external thread
	Connecting torque	10~12N·m
	Max. switching current (more than one cycle)	2500A300VDC
Auxiliary contact	Max. current	30VDC 2A; 125VAC 3A
	Min. current	8VDC 100mA
	Contact resistance	<0.15Ω

Coil parameter	
Rated voltage Us	12/24VDC
Operating voltage range	9~36 VDC
Pick up voltage	8~9 VDC
Release voltage	6~7 VDC
Coil power	holding: 3.2W
Inrush current	3.8A (0.1s) (@12V)
Holding current	0.267A@12V; 0.133A@24V
Pick up time (@Us)	≤45ms
Release time (@Us)	≤10ms
Bounce time (@Us)	≤5ms

Note: The above parameters are normal temperature rating, if other parameters needed, can customize.

Life characteristics		
Mechanical Life	300,000 cycles	
Resistivity load life (L/R≤1ms)	See next page	
Capacitive load life (RC=1ms , only for connecting)	600A	30,000 cycles
Note: For capacitive load life, when the contactor is used to control the main circuit of charge and discharge, the pre-charge circuit should be added. If there is no pre-charging path, a transient large current will be generated when the contactor closes, which may cause the contactor to stick.		

Electrical characteristics	
Dielectric withstand voltage	AC3000V
Insulation resistance	≥1000MΩ@1000VDC
Nominal insulation voltage Ui	1000V

Environmental characteristics		
Shock	Stability test	196m/s ² (20G)
	Strength test	490m/s ² (50G)
Resistance to vibration		10~2000Hz, 20G
Operating ambient temperature		-40℃~+85℃
Operating ambient humidity		5%~85% RH
IP Grade		IP67(inner space)
Altitude		≤4000m

Other	
Weight	550g, with auxiliary 555g
The cross sectional area of an external conductor	≥120mm ²
Case mounting hole torque	2.5~3.5 N·m

DC Contactor

Short overload capacity curve

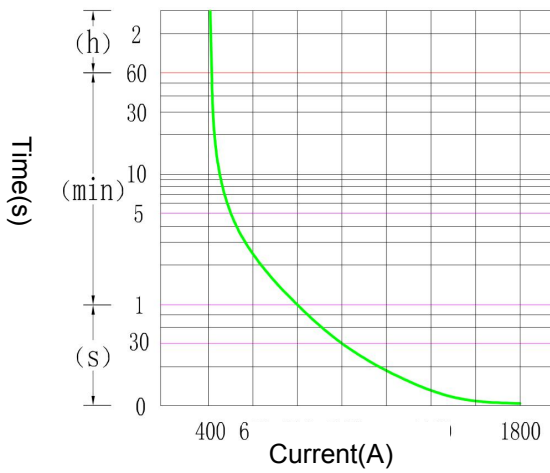

Cut-off life curve of resistive load

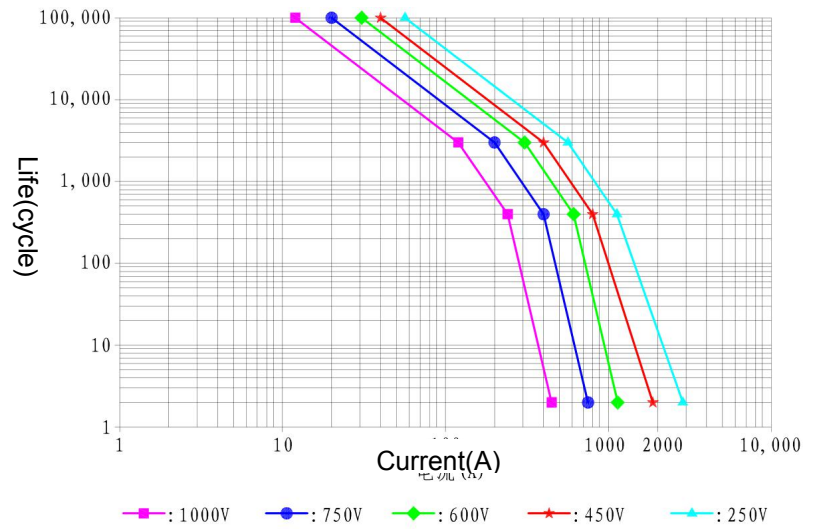

Note: Except for special note, the ambient temperature of electrical durability test is 23°C, and the on-break ratio is: 1s: 9s

Outline and wiring schematic diagram

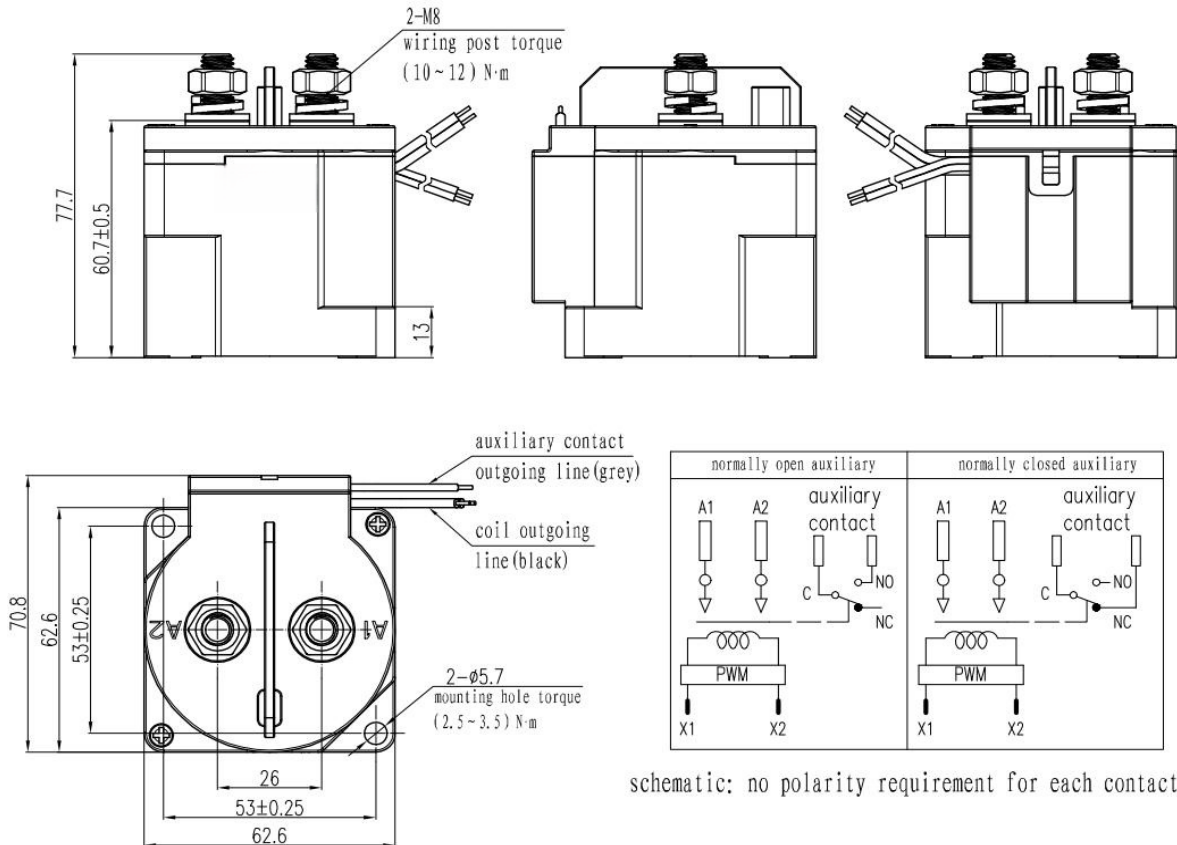

schematic: no polarity requirement for each contact

Note: Control coil wire length 300±20mm

Product without tolerance, when ≤10mm, tolerance ±0.3mm

When dimension between 10~50 mm, tolerance ±0.5mm

When dimension ≥50mm, tolerance ±0.8mm

DC Contactor