

FXC7 Series DC Contactor Specification

Customer	General Specification
Product Name	DC Contactor
Part Number	FXC7-150T-P FXC7-150TH-P FXC7-150TC-P FXC7-150TZ-P FXC7-150T-PW FXC7-150TH-PW FXC7-150TC-PW FXC7-150TZ-PW FXC7-150T-GY1 FXC7-150TH-GY1 FXC7-150TC-GY1 FXC7-150TZ-GY1 FXC7-150T-GWY1 FXC7-150TH-GWY1 FXC7-150TC-GWY1 FXC7-150TZ-GWY1
Date	2022/04/01
Validity	2 Year
Version	2022V1.0

DC Contactor

Feature

- Safe** : Fully sealed with epoxy resin, contact and coil will not be oxidized, product performance is not affected by external environment, no arc outbursts, can be worked in explosive and harmful environment.
- Reliable** : Adopt DC high voltage non-polarity design, the breaking capacity is higher and more reliable, convenient and reliable installation or wiring.
- Good for environment** : All components meet the latest ROHS environmental requirements.
- Application** : Ordinary, quick charging, auxiliary contactor. Can be used in EV, charging equipment, photovoltaic system, etc.
- Approval** : UL, CE, TUV

Ordering

FXC7-150 T H -P W Y1/XXX

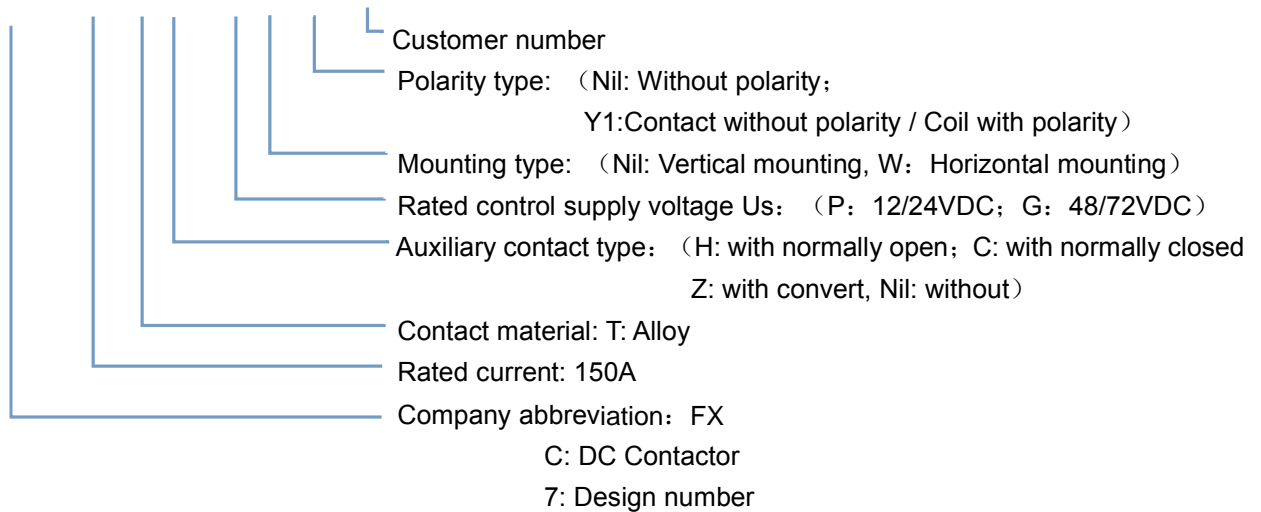

Basic Parameter

Contact parameter		
Main contact	Rated operational current I_e	150A
	Rated operational voltage U_e	12~1000VDC
	Min. load	1A12VDC
	Main contact type	1SH (SPST NO DM)
	Nominal resistance of main circuit	0.2 m Ω (@150A)
	Main contact mounting	M8 external thread
	Connecting torque	10~12N·m
	Max. switching current (more than one cycle)	1500A320VDC
Auxiliary contact	Max. current	30VDC 2A; 125VAC 3A
	Min. current	8VDC 100mA
	Contact resistance	<0.15 Ω

Coil parameter		
Rated voltage U_s	12/24VDC	48/72VDC
Operating voltage range	8~36 VDC	32~95 VDC
Pick up voltage	7~8 VDC	28~32 VDC
Release voltage	5~6 VDC	18~22 VDC
Coil power	holding: 2W	holding: 1.5W
Inrush current	3A (0.1s) (@12V)	1.3A (0.1s)
Holding current	0.17A@12V; 0.085A@24V	0.03A@48V; 0.02A@72V
Pick up time (@ U_s)	≤ 45 ms	≤ 45 ms
Release time (@ U_s)	≤ 10 ms	≤ 10 ms
Bounce time (@ U_s)	≤ 5 ms	≤ 5 ms

Note: The above parameters are normal temperature rating, if other parameters needed, can customize.

Life characteristics		
Mechanical Life	300,000 cycles	
Resistivity load life (L/R ≤ 1 ms)	See next page	
Capacitive load life (RC=1ms , only for connecting)	360A	50,000 cycles
Note: For capacitive load life, when the contactor is used to control the main circuit of charge and discharge, the pre-charge circuit should be added. If there is no pre-charging path, a transient large current will be generated when the contactor closes, which may cause the contactor to stick.		

Electrical characteristics	
Dielectric withstand voltage	AC3000V
Insulation resistance	≥ 1000 M Ω @1000VDC
Nominal insulation voltage U_i	1000V

Environmental characteristics		
Shock	Stability test	196m/s ² (20G)
	Strength test	490m/s ² (50G)
Resistance to vibration		10~2000Hz, 20G
Operating ambient temperature		-40 $^{\circ}$ C~+85 $^{\circ}$ C
Operating ambient humidity		5%~85% RH
IP Grade		IP67(inner space)
Altitude		≤ 4000 m

Other	
Weight	425g, with auxiliary 430g
The cross sectional area of an external conductor	≥ 50 mm ²
Case mounting hole torque	2.5~3.5 N·m

DC Contactor

Short overload capacity curve

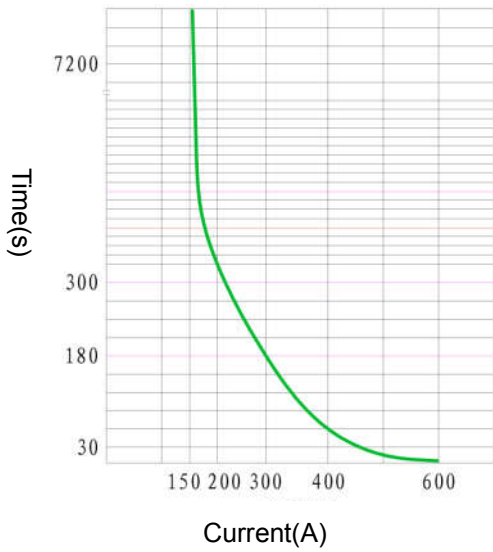

Cut-off life curve of resistive load

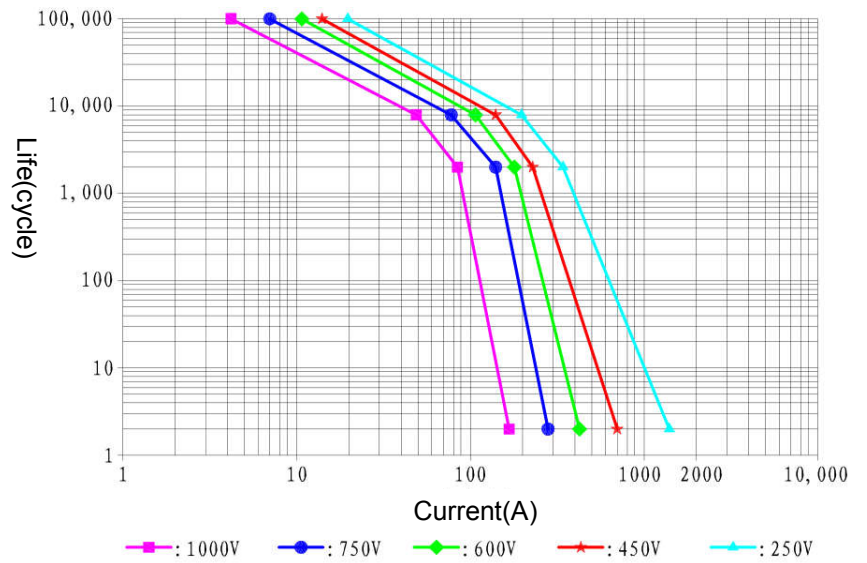

Note: Except for special note, the ambient temperature of electrical durability test is 23°C, and the on-break ratio is: 1s: 9s

Outline and wiring schematic diagram

Vertical mounting structure:

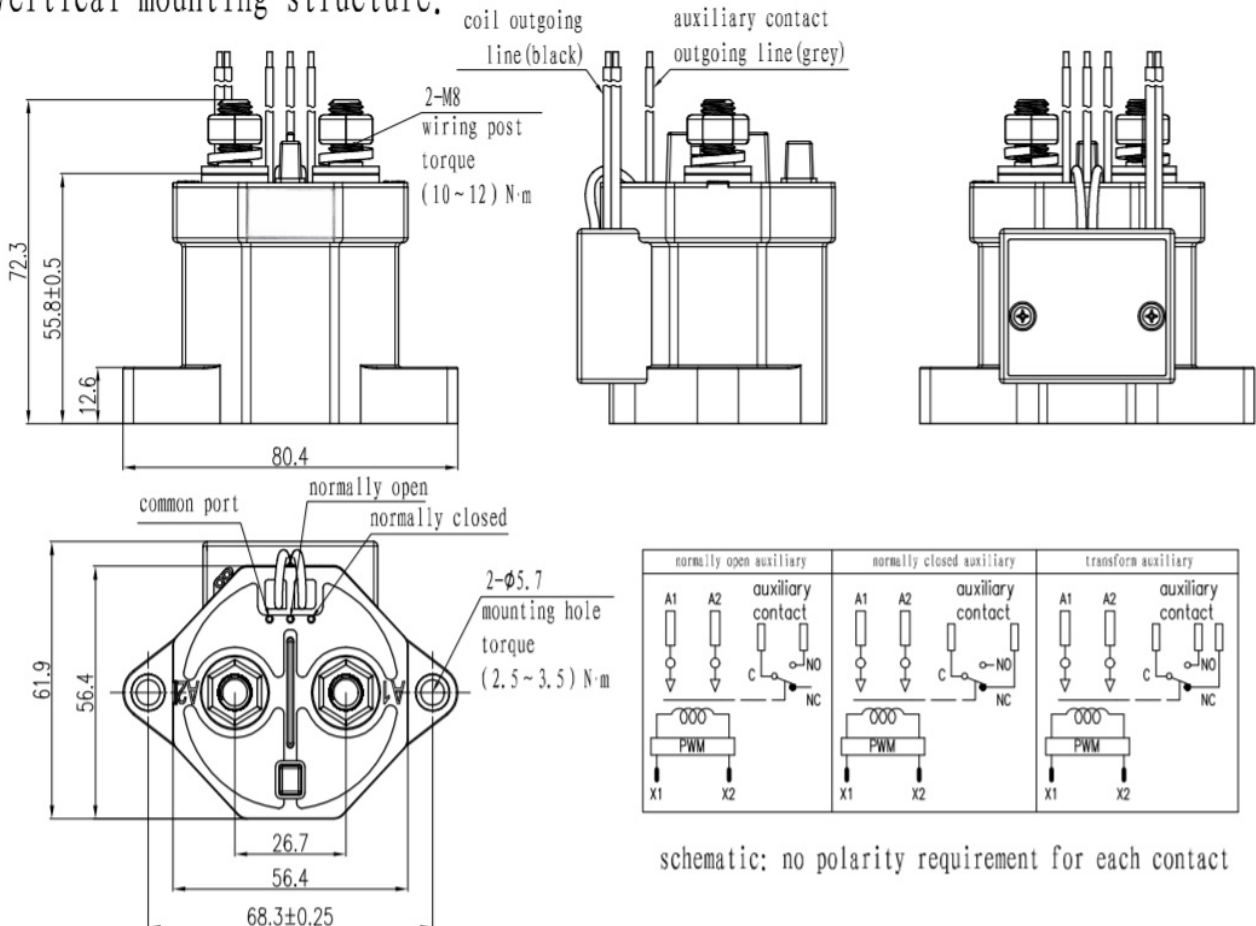

schematic: no polarity requirement for each contact

Horizontal mounting structure:

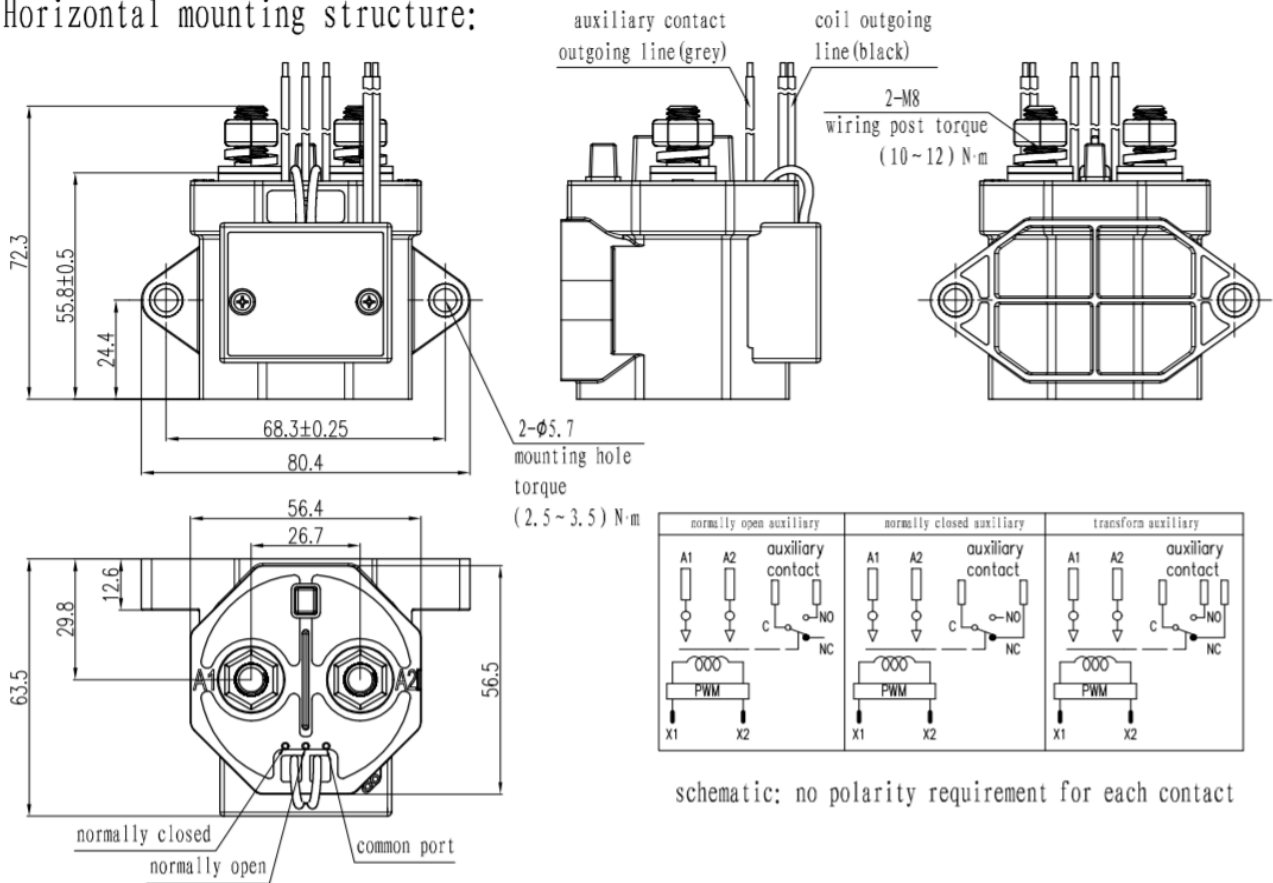

schematic: no polarity requirement for each contact

Note: Control coil wire length 300±20mm

Product without tolerance, when ≤10mm, tolerance ±0.3mm

When dimension between 10~50 mm, tolerance ±0.5mm

When dimension ≥50mm, tolerance ±0.8mm

DC Contactor